

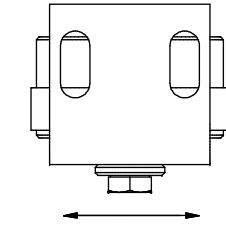

B-B (1:2)

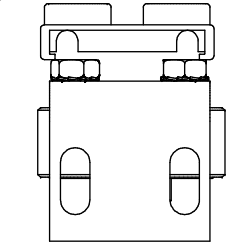
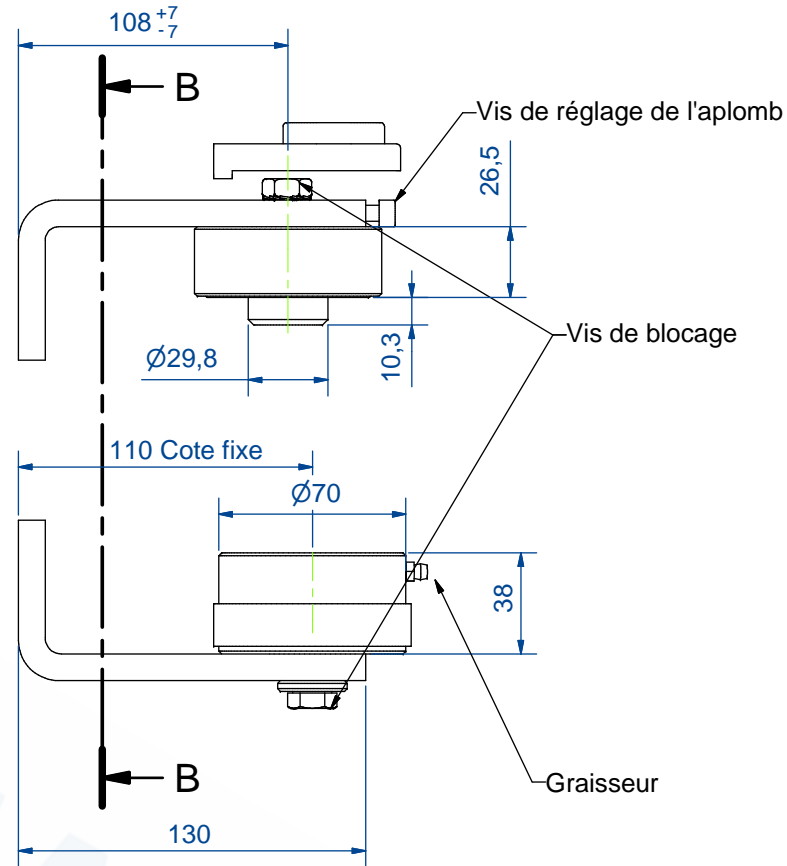
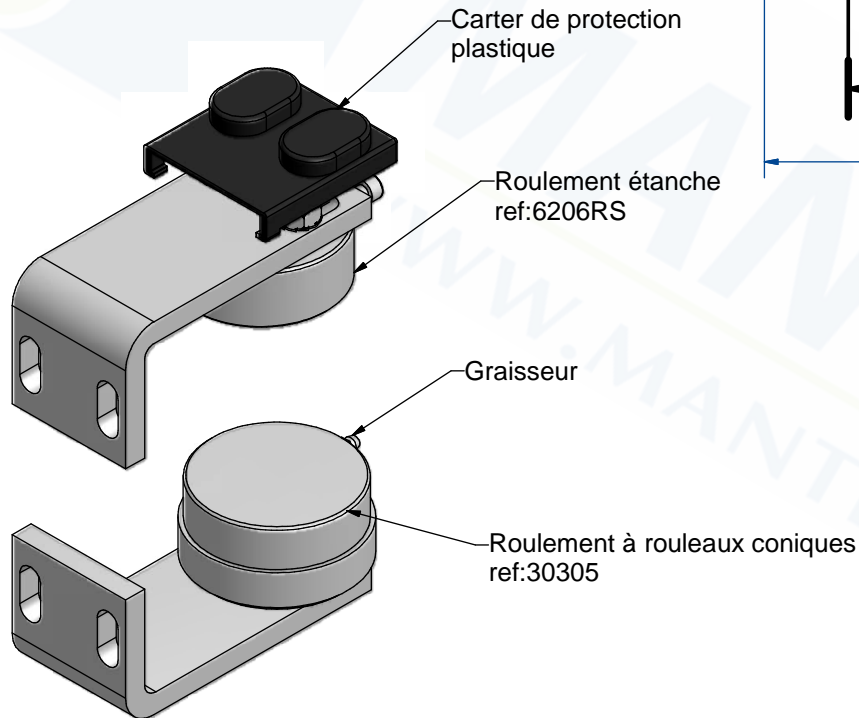
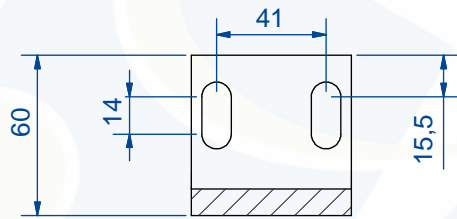
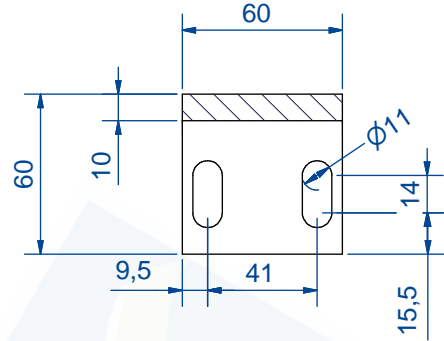

Réglage partie basse ± 6mm

Indice	Date	Modifications		
Désignation: PIVOTS Diam 70		Rugosité:	Traitement:	Tolérance gén:
		Dessiné par: LC	Bichromatation	+/- 0,5mm
 7,rue Gay Lussac 25000 BESANCON		Date: 12.05.05	Matière: Acier S235	
		Ech: 1/2	Code Mat:	
PLAN N°		Ensemble: pivots 25072		
25072				
Ce plan est la propriété de la Sté MANTION et ne peut être reproduit ou communiqué à des tiers sans son autorisation				